

6-8-10MS

MOTORI SOMMERSI 6"-8"-10"
6"-8"-10" SUBMERSIBLE MOTORS
MOTEURS IMMERGÉS 6"-8"-10"
PONORNÉ MOTORY 6"-8"-10"

subteck

Caratteristiche costruttive

Motori sommersi 6"-8"-10" riavvolgibili a bagno d'acqua con aggiunta di glicole propilenico. Albero con dentatura standard NEMA 6"-8"-10" in acciaio Duplex® Camicia esterna avvolgimento in acciaio inox AISI 304 Bulloneria e sistemi di fissaggio in acciaio inox AISI 304

Cavo motore da 4 m DRINCABLE® (approvato da ACS e WRAS)

Cuscinetto reggispinta tipo Kingsbury Senso di rotazione oraria o antioraria.

Protezione: la protezione del motore deve essere fornita dal cliente attraverso la selezione di relè termici secondo le norme EN 60947-4-1, classe di scatto 10 o 10A, intervallo di scatto <10s a 5x In.

Tutti i motori sono collaudati al 100%

Construction features

Rewindable, water cooled, added with propylene glycol, immersed Motors 6"-8"-10". Shaft with teeth of Duplex® steel, according to Standard Nema for 6"-8"-10".

Winding outer shell made in s.s. AISI 304.

Bolts, nuts and fixing system made in s.s. AISI 304.

Motor cable 4 metres DRINCABLE® (approval ACS and WRAS)

Trust bearing: Kingsbury Rotation: clockwise/anti-clockwise.

Protection: motor protection should be made by final user through a selection of thermal relays according rules EN 60947-4-1, kick class 10 or 10A, Trip time <10s to 5x In.

All motors are 100% tested.

Caractéristiques de construction

Moteurs immergés 6"-8"-10" rebobinables, en bain d'eau avec addition de glycolepropilène.

Arbre en acier Duplex® avec denture selon Standard Nema 6"-8"-10".

Chemise moteur en acier inox AISI 304.

Boulonnerie et systèmes de fixation en acier inox AISI 304.

Câble: 4 m câble moteur DRINCABLE® (approuvé par ACS et WRAS).

Palier de butée du type Kingsbury.

Rotation: horaire/antihoraire.

Protection: la protection du moteur doit être faite par le client, utilisant la sélection des relais thermiques selon les normes EN 60947-4-1, classe d'unité 10 ou 10A, Trip time <10s à 5x In..

Tous les moteurs sont essayés au 100%.

Konstrukční vlastnosti

Převinutelné, vodou chlazené, s přidávkou propylenglykolu, ponorné motory 6"-8"-10". Hřídel se zuby z oceli Duplex® ocel, podle standardu Nema pro 6"-8"-10".

Navíjecí vnější plášť vyrobený z nerez. oceli AISI 304.

Šrouby, matice a upevňovací systém vyrobený z nerez. oceli AISI 304.

Motorový kabel 4 metry DRINCABLE® (schválení ACS a WRAS)

Axiální ložisko: Kingsbury Rotace: ve směru/proti směru hodinových ručiček.

Ochrana: Ochrana motoru by měla být provedena konečným uživatelem prostřednictvím výběru tepelných relé podle pravidel EN 60947-4-1, třída vypnutí 10 nebo 10A, doba vypnutí <10s až 5x In.

Všechny motory jsou 100% testovány.



Dati di esercizio

Motore ad induzione a 2 poli, 50 Hz ($n \approx 2900$ 1/min).

Dimensioni per il collegamento alla pompa secondo NEMA Standards.

Tensioni di alimentazione: trifase 230 V; 400 V.

Variazione di tensione: +6%/-10%.

Avvolgimento standard in PVC

Protezione IP 68.

Motore predisposto per funzionamento con inverter.

Operation data

2-pole induction motor, 50 Hz ($n \approx 2900$ rpm).

Sized for connection to the pumps according to NEMA Standards.

Standard voltages: three-phase 230 V; 400 V.

Voltage tolerance: +6% / -10%.

Winding standard in PVC.

Protection IP 68.

Motor suitable operation with frequency converter.

Données de fonctionnement

Moteur à induction à 2 pôles, 50 Hz ($n \approx 2900$ 1/min).

Dimensions pour connexion à la pompe selon normes NEMA.

Alimentation électrique: triphasée 230 V; 400 V.

Variation de voltage: +6% / -10%

Bobinage: Standard en PVC.

Protection IP 68.

Moteur préparé pour fonctionnement avec variateur de fréquence.

Provozní parametry

2-pólový indukční motor, 50 Hz ($n \approx 2900$ ot./min.).

Dimenzováno pro připojení k čerpadlům podle norem NEMA.

Standardní napětí: třífázové 230 V; 400 V.

Tolerance napětí: +6% / -10%.

Standardní vinutí z PVC.

Krytí IP 68.

Motor vhodný pro provoz s frekvenčním měničem.

6-8-10MS

MOTORI SOMMERSI 6"-8"-10"
6"-8"-10" SUBMERSIBLE MOTORS
MOTEURS IMMERGÉS 6"-8"-10"
MOTORES SUMERGIDOS 6"-8"-10"

subteck

Limiti d'impiego

Massima temperatura del liquido 30°C(6MS-8MS) 45°C (10MS).

Minima velocità flusso di raffreddamento:

4kW÷15kW =0,20m/s (6MS)

18,5 kW ÷ 37kW= 0.50 m/s (6MS)

22kW ÷ 52kW =0,20m/s (8MS)

55kW ÷ 110kW= 0.50 m/s (8MS)

0.20m/s (10MS)

Installazione: verticale/orizzontale (i motori da 93-110-150-170-190kW non possono funzionare in orizzontale).

Massimo numero di avviamenti ora = 20 (6MS-8MS) 6(10MS).

Servizio continuo.

Operating conditions

Max. Liquid temperature 30°C(6MS-8MS) 45°C (10MS).

Cooling minimum flow velocity:

4kW÷15kW =0,20m/s (6MS)

18,5 kW ÷ 37kW= 0.50 m/s (6MS)

22kW ÷ 52kW =0,20m/s (8MS)

55kW ÷ 110kW= 0.50 m/s (8MS)

0.20m/s (10MS)

Installation: vertical/horizontal (the motors 93-110-150-170-190kW cannot work horizontal size).

Maximum number of starts per hour = 20 (6MS-8MS) 6(10MS).

Continuous duty.

Limites d'utilisation

Température maximale du liquide 30°C(6MS-8MS) 45°C(10MS).

Refroidissement vitesse minimum du flux:

4kW÷15kW =0,20m/s (6MS)

18,5 kW ÷ 37kW= 0.50 m/s (6MS)

22kW ÷ 52kW =0,20m/s (8MS)

55kW ÷ 110kW= 0.50 m/s (8MS)

0.20m/s (10MS)

Installation: Verticale/horizontale (les moteurs de 93-110-150-170-190kW ne peuvent pas fonctionner en horizontal).

Nombre de démarrages maximum par heure = 20 (6MS-8MS) 6(10MS).

Service continu.

Pracovní podmínky

Max. Teplota kapaliny 30 °C (6MS-8MS) 45 °C (10MS).

Minimální rychlost proudění chlazení:

4kW÷15kW =0,20 m/s (6MS)

18,5 kW ÷ 37 kW= 0,50 m/s (6MS)

22kW ÷ 52kW =0,20 m/s (8MS)

55kW ÷ 110kW= 0,50 m/s (8MS)

0,20 m/s (10 MS)

Instalace: vertikální/horizontální (motory 93-110-150-170-190kW nemohou pracovat v horizontální poloze).

Maximální počet startů za hodinu = 20 (6MS-8MS) 6(10MS).

Nepřetržitý provoz.

Esecuzioni speciali a richiesta

Tensioni speciali a richiesta. Avviamento : Y/Δ (posizione cavi a 90°)

Avvolgimenti con isolamento PE2/PA per temperature max 50°C

Sensore di temperatura PT100, da ordinare separatamente

Exécutions spéciales sur demande

Special Voltages. Starting wise: Y/Δ (cable will be positioned at 90°).

Windings equipped with Insulation PE2/PA for temp. max. 50°C.

Temperature sensor PT100.

Other features on request

Voltages spéciaux. Démarrage: Y/Δ (les câbles sont positionnés à 90°).

Bobinages avec isolation PE2/PA pour de températures max. de 50°C.

Détecteur de température PT100.

Další funkce na vyžádání

Speciální napětí. Startování: Y/Δ (kabel bude umístěn pod úhlem

90°). Vinutí vybavená izolací PE2/PA pro tepl. max. 50 °C.

Snímač teploty PT100.

6MS

MOTORI SOMMERSI 6"-8"-10"
 6"-8"-10" SUBMERSIBLE MOTORS
 MOTEURS IMMERGES 6"-8"-10"
 PONORNÉ MOTORY 6"-8"-10"



	Rated power		Efficiency 4/4	Power Factor 4/4	Rated current A		RPM	starts/hour	Starting				
	kW	HP			230V	400V			Direct		Star/Delta	Statoric	
			%	cosφ			Ma/Mn	la/ln	la/ln	la/ln			
6MS 400	4	5,5	79,5	0,83	16	9,5	2880	10	max	1,97	5,20	1,3	3,6
6MS 550	5,5	7,5	78	0,87	21,5	12,5	2850		1,80	4,90	1,6	3,4	
6MS 750	7,5	10	78,5	0,86	29,5	17	2850		2,06	5,35	1,7	3,7	
6MS 920	9,2	12,5	78	0,86	36	21,5	2830		1,99	5,05	1,7	3,5	
6MS 1100	11	15	79	0,87	42,5	24,5	2840		1,91	5,00	1,6	3,6	
6MS 1300	13	17,5	80	0,86	51	29	2840		1,91	5,00	1,6	3,6	
6MS 1500	15	20	81	0,86	60	34	2830		2,21	5,05	1,6	3,5	
6MS 1850	18,5	25	82	0,85	69,5	40	2845		2,02	4,85	1,6	3,4	
6MS 2200	22	30	83	0,86	83	48	2845		1,82	4,60	1,5	3,2	
6MS 2600	26	35	82,5	0,87	95	55	2830		1,70	4,90	1,6	3,4	
6MS 3000	30	40	83	0,84	113,5	65,5	2840	8	1,97	5,15	1,7	3,6	
6MS 3700	37	50	83	0,85	138,5	80	2840		1,80	4,75	1,5	3,3	
6MS 4500	45	60	83	0,85	167	96,5	2840		1,85	5,05	1,6	3,4	

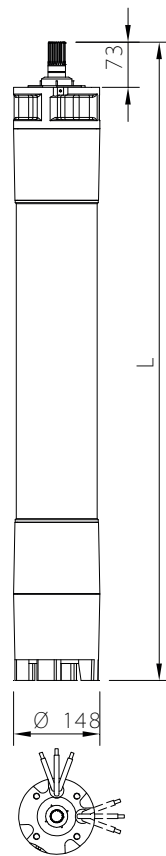

Sezione Section (mm ²)	 (mm)
1x4	7,5
1x6	8
1x10	9
1x16	10,5
1x25	12,5

6" NEMA

Type	L	cable length	cable section				Max water °C		Axial Thrust	Weight	
			direct		star/delta		PVC	PE2+PA			
	mm	mt	230V	400V	230V	400V			N	Kg.	
6MS 400	670	3,5	(1x4)x3	(1x4)x3	(1x4)x6	(1x4)x6	30	55	18000	44	
6MS 550	700									46	
6MS 750	740									50	
6MS 920	770									54	
6MS 1100	840									61	
6MS 1300	840									62	
6MS 1500	900		(1x6)x3	(1x6)x3	(1x6)x6	(1x6)x6	30	55	18000	68	
6MS 1850	970									75	
6MS 2200	1040		4,5	(1x10)x3	(1x10)x3	(1x10)x6	(1x6)x6	25	45	25000	82
6MS 1300	840										62
6MS 2600	1100	89									
6MS 3000	1240	103									
6MS 3700	1370	-	(1x10)x3	(1x10)x6	(1x6)x6	25	45	25000	116		
6MS 4500	1400	-	(1x10)x3	(1x10)x6	(1x10)x6	-	45	25000	121		

6MS

MOTORI SOMMERSI 6"-8"-10"
6"-8"-10" SUBMERSIBLE MOTORS
MOTEURS IMMERGÉS 6"-8"-10"
PONORNÉ MOTORY 6"-8"-10"



10 Ricambi - Spare parts - Náhradní díly

6F

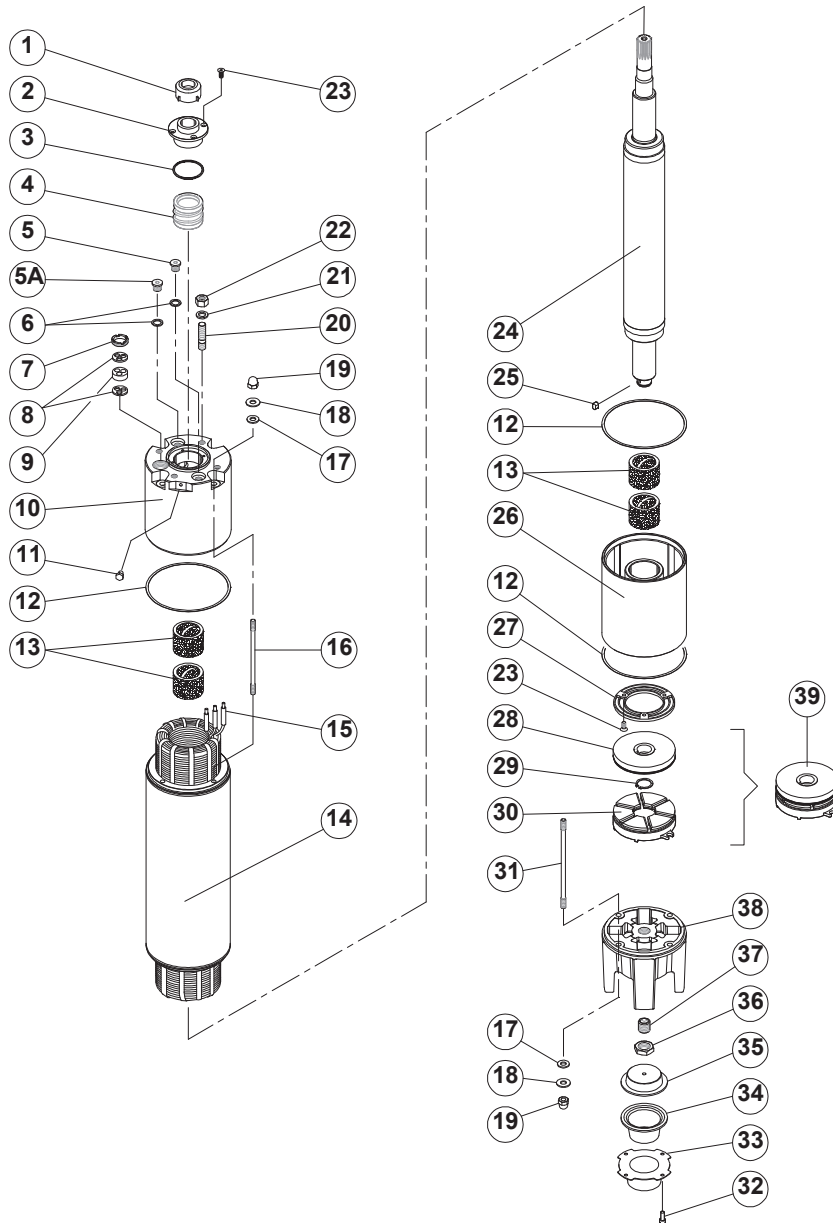

Pos.	Qt.	Denominazione	Denomination	Denomination
1	1	Parasabbia	Sand guard	Para-sable
2	1	Coperchio	Cover	Couvercle
3	1	Guarnizione	Gasket	Garniture
4	1	Tenuta meccanica	Mech. seal	Garniture mécan.
5	1	Tappo	Plug	Bouchon
5A	1	Valvola	Valve	Clapet
6	2	Rondella	Washer	Rondelle
7	1/2	Ghiera pressacavo	Ring nut	Bague
8	2/4	Piastrina pressacavo	Cable-press	Prese-câble
9	1	Guarnizione pressacavo	Gasket	Garniture
10	1	Supporto superiore	Upper Support	Support supérieur
11	1	Vite di terra	Screw	Vis
12	2	Guarnizione	Gasket	Garniture
13	2/3/4	Bussola	Seal bushing	Douille
14	1	Statore	Stator	Stator
15	3/6	Cavo tondo unipolare	Single core round cable	Câble rond unipolaire
16	4	Tirante superiore	Tension rod	Goujon
17	8	Guarnizione	Gasket	Garniture
18	8	Rondella	Washer	Rondelle
19	8	Dado cieco	Nut	Ecrou

Pos.	Qt.	Denominazione	Denomination	Denomination
20	4	Prigioniero	Stud	Goujon
21	4	Rondella	Washer	Rondelle
22	4	Dado	Nut	Ecrou
23	7	Vite svasata	Screw	Vis
24	1	Rotore	Rotor	Rotor
25	1	Linguetta	Key	Clavette
26	1	Supporto inferiore	Lower support	Support inférieur
27	1	Contropattino	Striker disk	Disque de rep.
28	1	Ralla	Thrust disk	Disque de butée
29	1	Anello elastico	Seeger ring	Bague seeger
30	6	Pattino	Thrust sliding	Patins de butée
31	4	Tirante inferiore	Tension rod	Goujon
32	1	Vite	Screw	Vis
33	1	Coperchio esterno	Cover	Couvercle
34	1	Membrana	Membrane	Membrane
35	1	Coperchio interno	Cover	Couvercle
36	1	Dado	Nut	Ecrou
37	1	Vite di registrazione	Screw	Vis
38	1	Fondello	Bottom	Bout
39	1	Gruppo reggispira	Complete thrust bearing	Butée complete